

# ANALOG INDUCTIVE CURRENT OUTPUT ANALOG SENSOR

M 12
●
0.1-3.0mm
Nickel plated brass
○

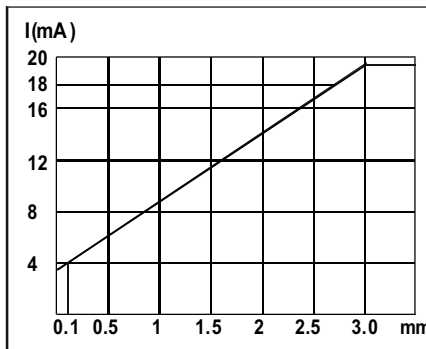

18-30VDC
<10%
<35mA
-
4-20mA/400Ω Max.
<5%
0.02mm
0°C ~ +70°C
<5% (Sr)
-
YES
IP67
PNP-ANALOG
100Hz
-
RFI>3V/m / EFT>1KV / ESD>4KV (contact)
IEC 60947-5-2,Part 7.4.1 / IEC 60947-5-2,Part 7.4.2
PBT



P5C1B1202GI3A2	18	P5C1B1202GIEA4
----------------	----	----------------

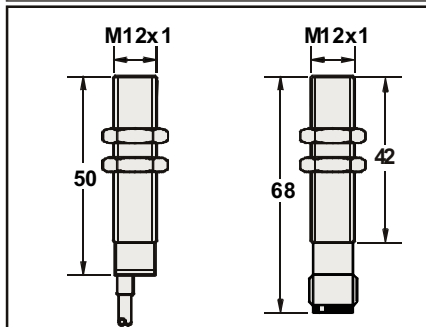

4φ3x0.15	-
approx.67g	approx.30g

M 12
○
0.1-4 mm
Nickel plated brass
○



18-30VDC
<10%
<35mA
-
4-20mA/400Ω Max.
<5%
0.02mm
0°C ~ +70°C
<5% (Sr)
-
YES
IP67
PNP-ANALOG
100Hz
-
RFI>3V/m / EFT>1KV / ESD>4KV (contact)
IEC 60947-5-2,Part 7.4.1 / IEC 60947-5-2,Part 7.4.2
PBT

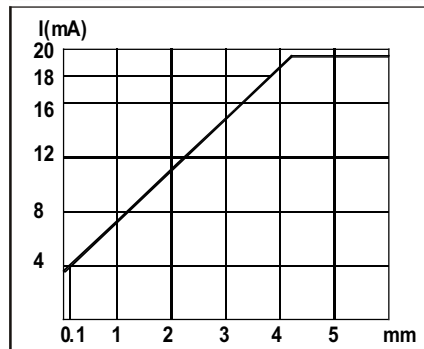

P5C2B1204GI3A2	18	P5C2B1204GIEA4
----------------	----	----------------

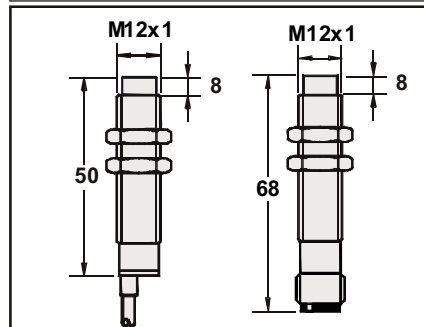

4φ3x0.15	-
approx.67g	approx.30g

M 18
●
1-4 mm
Nickel plated brass
○



18-30VDC
<10%
15mA
-
0-20mA/200Ω Max.
<10% (Sr)
0.02mm
0°C ~ +70°C
5% (Sr)
-
YES
IP67
PNP-ANALOG
100Hz
-
RFI>3V/m / EFT>1KV / ESD>4KV (contact)
IEC 60947-5-2,Part 7.4.1 / IEC 60947-5-2,Part 7.4.2
PBT

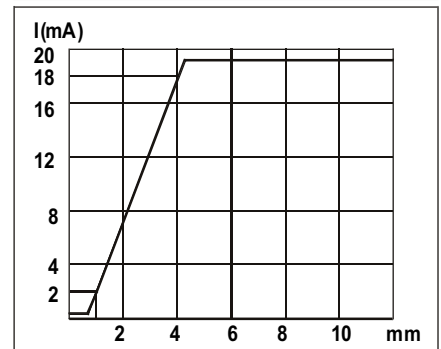

P5C1B1804GI3A2	18	P5C1B1804GIEA4
----------------	----	----------------

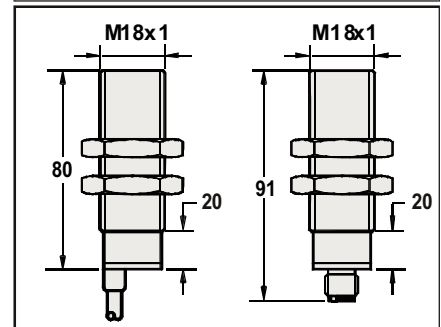

5.8φ3x0.5	-
approx.142g	approx.69g

# ANALOG INDUCTIVE CURRENT OUTPUT ANALOG SENSOR

<b>Diameter</b>	
● Shielded	○ non-shielded
Switching Distance, Sn: mm	
Housing Material	
● With LED	○ Without LED

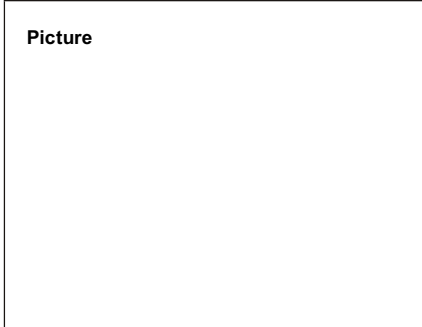

Supply Voltage
Max. Ripple
No Load Current
Output Voltage/Load Resistor
Output Current/Load Resistor
Linearity
Repeat Accuracy
Ambient Temperature
Temperature Drift
Short Circuit Protection
Reverse Polarity Protection
Protection Degree
Output Signal
Switch Frequency Max.
Time Delay Before Availability
EMC
Shock / Vibration
Material Active Face

Characteristics

Inductive Voltage Output
Inductive Current Output
Inductive Voltage & Current output

Dimensions (Unit: mm)

Cable 2M (PVC)
Weight

<b>M 18</b>
○
1-7 mm
Nickel plated brass
○



18-30VDC
<10%
15mA
-
0-20mA/200Ω Max.
<10%(Sr)
0.02mm
0°C ~ +70°C
5%(Sr)
-
YES
IP67
PNP-ANALOG
100Hz
-
RFI>3V/m / EFT>1KV / ESD>4KV (contact)
IEC 60947-5-2,Part 7.4.1 / IEC 60947-5-2,Part 7.4.2
PBT

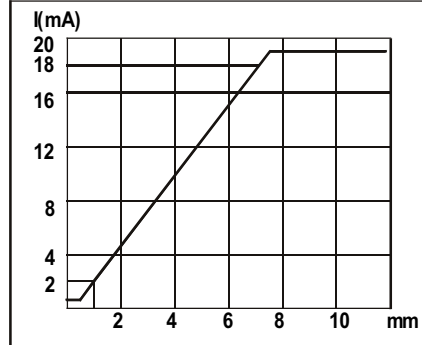

P5C2B1807GI3A2	18	P5C2B1807GIEA4
-	-	-

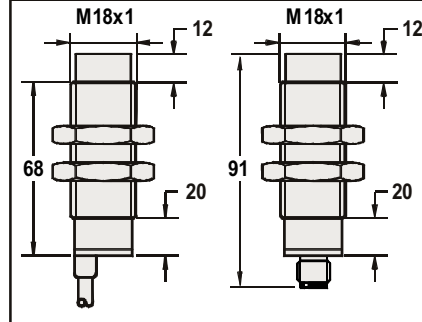

5.8φ3x0.5	-	-
approx.142g	approx.69g	-

<b>M 30</b>
●
5-10 mm
Nickel plated brass
○



18-30VDC
<10%
15mA
-
0-20mA/200Ω Max.
<10%(Sr)
0.02mm
0°C ~ +70°C
5%(Sr)
-
YES
IP67
PNP-ANALOG
100Hz
-
RFI>3V/m / EFT>1KV / ESD>4KV (contact)
IEC 60947-5-2,Part 7.4.1 / IEC 60947-5-2,Part 7.4.2
PBT

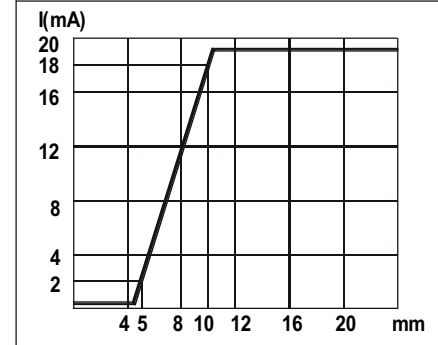

P5C1B3010GI3A2	18	P5C1B3010GIEA4
-	-	-

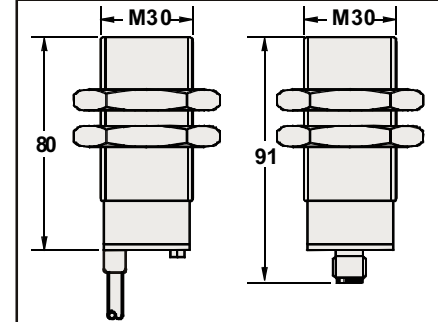

5.8φ3x0.5	-	-
approx.252g	approx.187g	-