



Description of the hygrostat

The humidity measuring element, produced by Galltec under the name Polyga®, consists of several synthetic fabric bands each with 90 individual fibres with a diameter of 3µm. A special process gives the fibre hygroscopic properties. The measuring element absorbs and desorbs humidity. The swelling effect, which is predominantly in a lengthways direction, is carried via a suitable lever system to a microswitch with an extremely small switching path. The measuring element reacts quickly and precisely to the change in air humidity. By adjusting the setpoint value control knob, the lever system is engaged so that when the set air humidity is reached the microswitch is activated.

In the case of the hygrostat type HG120-2, a second microswitch is positioned parallel to the first microswitch. After the housing cover has been removed, the second set value can be finely adjusted at the microswitch lever using a screwdriver. The switch point of the second microswitch is connected to the switch point of the first microswitch. The switch distance (neutral zone) can be set from 3%rh to +15%rh.

The fan-shaped measuring element is accommodated inside the housing and must be protected against coarse dust, dirt and water. The sensors are designed for pressureless systems. The mounting position should be chosen such that condensed water cannot get into the interior of the housing. Any mounting position is possible, preferably with ventilation slots across the direction of wind.

Maintenance

The measuring element is maintenance-free in pure ambient air. Aggressive media containing solvent can cause measuring errors and failure, depending on the type and concentration. As with almost all humidity measuring elements, deposits which eventually form a water-repellent film over the measuring element are harmful (such as resin aerosols, lacquer aerosols, smoke deposits etc.).

NOTE:

Contact with the inner parts nullifies the guarantee.

Room Hygrostat

- with Polyga®- humidity measuring element **HG120**
- with one or two changeover contacts **HG120-2**
- or inner rotary knob **HG120i**
- HG120-2i**

Application

The hygrostat type **HG120** is used as an on-off controller to control the relative air humidity in climatic cabinets, to control air humidifiers and dehumidifiers in offices and computer rooms. Other areas of use are storage of foodstuffs and luxury foods, cooling rooms for fruit and vegetables, greenhouses for gardening use, the textile industry, the paper and printing industry, the film industry and hospitals. The hygrostat **HG120** can be used almost anywhere that air humidity has to be regulated or monitored.

The room hygrostat **HG120-2** is equipped with a 2nd microswitch. It can be used as a 2-level controller or as a max-min controller.

Room hygrostats with adjusting knob and internal scale are available for all variations. The type designation has a small „i“ at the end, e.g. **HG120i**.

Technical Data

- scale range 30...100%rh
- measuring accuracy ±3%rh
- range of operation 35...95%rh
- switching difference (microswitch) ref. to 50%rh approx. 4%rh
- breaking capacity
- max. 250VAC and
- 0,1 ... 5A ohmic load for dehumidifying
- 0,1 ... 2A ohmic load for humidifying
- 0,1 ... 1A for inductive load with cos φ = 0,7
- lifetime 100.000 breaking cycles

Please observe the notes on voltage.

optional microswitch with gold contact

- breaking capacity
- max. 48 VAC and
- 1...100 mA
- allowable ambient temperature 0...60°C
- medium temp. coefficient -0.2%/K rel.to 20°C and50%rh
- adjustment at average air pressure 430 m NN
- allowable air speed 15m/sec
- t50 at v=2m/sec 1.2min
- fixing slots in housing base
- mounting position optional
- contacting connecting terminals
- electromagnetic compatibility
- directive 2006/95/EG
- applied standards
- DIN EN 60730-1 issue 12/05
- DIN EN 60730-2-13 issue 09/02
- protective system IP20
- measuring element
- Polyga®-measuring element, water resistant
- dimensions 85x55x33 mm
- weight approx. 0.70 kg

This information is based on current knowledge and is intended to provide details of our products and their possible applications. It does not, therefore, act as a guarantee of specific properties of the products described or of their suitability for a particular application. It is our experience that the equipment may be used across a broad spectrum of applications under the most varied conditions and loads. We cannot appraise every individual case. Purchasers and/or users are responsible for checking the equipment for suitability for any particular application. Any existing industrial rights of protection must be observed. The perfect quality of our products is guaranteed under our General Conditions of Sale. Issue : January 2011 HG120_e. Subject to modifications.

Dimensions diagram

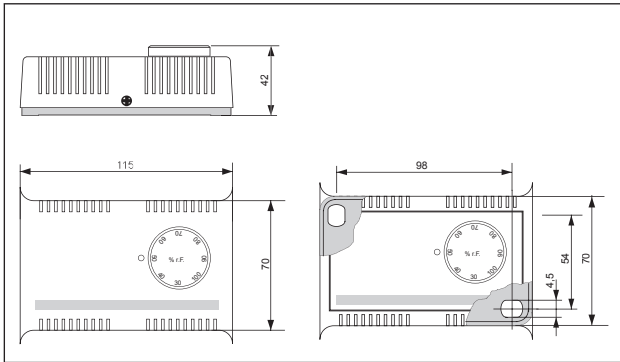

Type Survey

Type	Order no.	Type of contact
HG120	42042011	changeover contact: 1 x max. 5 A
HG120-2	42042221	changeover contact: 2 x max. 5 A
HG120i	42042012	changeover contact: 1 x max. 5 A, with internal scale
HG120-2i	42042222	changeover contact: 2 x max. 5 A, with internal scale

Note:
Moving the adjuster screw nullifies the guarantee.

Slot diagram

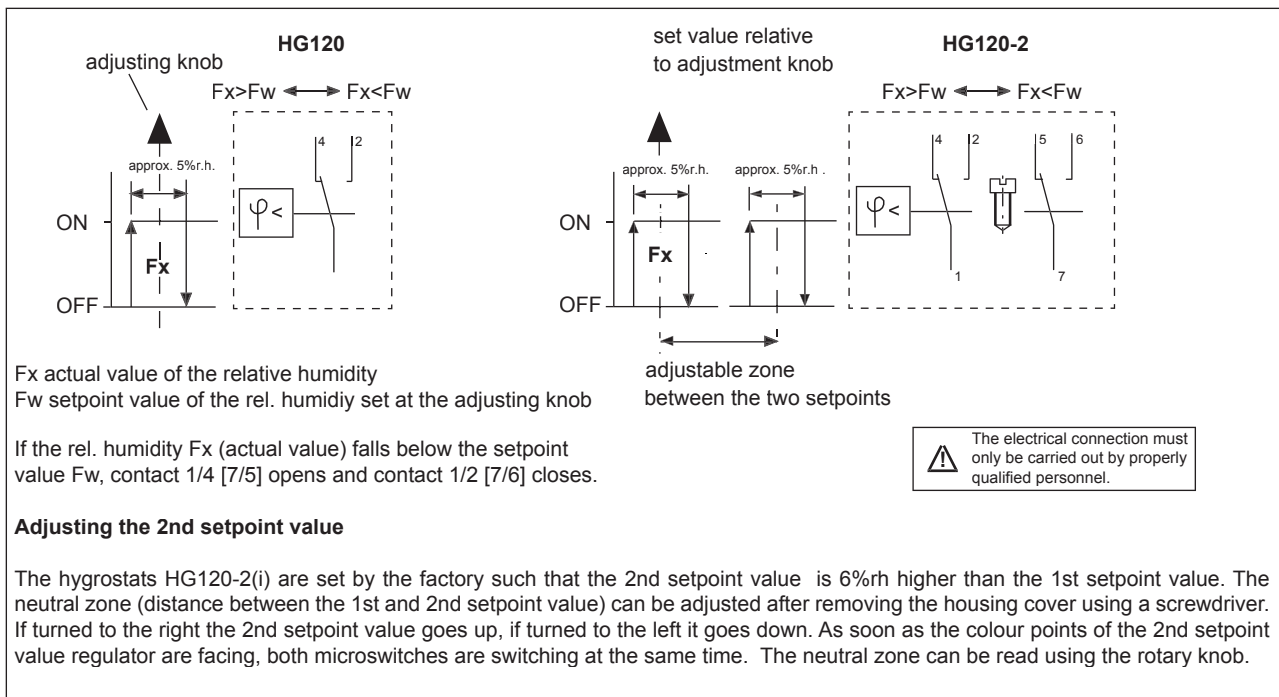

Mounting

- The hygrostat must not come into direct contact with water, e.g. splashed water when cleaning the climatic chamber etc.
- The mounting location should be chosen so that a representative measurement of the air humidity can be guaranteed, i.e. the humidity readings at the mounting location should correspond to those in the room.
- The hygrostat should be exposed to the flow of air.

Physical influence of temperature on the relative air humidity

at a temperature fluctuation of $\pm 1K$ referred to various room temperatures.

	10°C	20°C	30°C	50°C
10%rh	+/-0,7%rh	+/-0,6%rh	+/-0,6%rh	+/-0,5%rh
50%rh	+/-3,5%rh	+/-3,2%rh	+/-3,0%rh	+/-2,6%rh
90%rh	+/-6,3%rh	+/-5,7%rh	+/-5,4%rh	+/-4,6%rh

It is thus of extreme importance that the temperature is constant for measurements of the relative air humidity. The air must be homogenous.

Notes on voltage

The measurement location of the humidity controller should be selected such that there is no build-up of condensate on or in the device. This applies particularly for operation with a voltage higher than 48V. If the voltage is higher, there is a risk of voltage arcing in the event of water condensation on the microswitch or connecting terminals which might destroy the controller. In the case of voltage below 48V, the humidity controller can be used up to 100%rh.